



# Technical Brief

## PureVideo

Digital Home Theater Video  
Quality for Mainstream PCs with  
GeForce 6 and 7 GPUs



# Table of Contents

<b>Digital Home Theater Video Quality for Mainstream PCs with GeForce 6 and 7 GPUs.....</b>	<b>3</b>
Background.....	3
PureVideo Video Processor on GeForce 6 and 7 Series GPUs.....	3
PureVideo Adapts to New Standards.....	4
Video Recording (Encode).....	7
Motion Estimation Engine (MEE).....	8
High-Definition MPEG-2 Hardware Acceleration.....	9
WMV HD Hardware Acceleration.....	10
Advanced Spatial-Temporal De-Interlacing.....	11
Inverse Telecine (3:2 and 2:2 Pull-Down Correction).....	13
Bad Edit Detection and Correction.....	16
Multistream VMR Scaling.....	17
LCD Sharpening.....	18
PureVideo on the Go.....	19
CPU Utilization.....	19
Conclusion.....	20



# Digital Home Theater Video Quality for Mainstream PCs with GeForce 6 and 7 GPUs

---

## Background

Today's consumers want fluid, crystal-clear digital video, whether they are using a PC or consumer electronics (CE) device. They also demand better than DVD-quality television recording and playback on their high-definition monitors and televisions.

CE video players use expensive video processors to perform effects like progressive scan de-interlacing, inverse telecine (also known as 3:2 and 2:2 pull-down correction), and video scaling. PC-based video often compromised the video quality during recording and playback because of the limited processing capabilities of the CPU. The NVIDIA® GeForce® 6 and 7 Series GPUs with NVIDIA PureVideo™ technology add the video processing horsepower needed to overcome the PC video compromise and provide crisp, clear, stutter-free, vibrant high-definition video that rivals the finest high-end home theater systems today.

---

## PureVideo Video Processor on GeForce 6 and 7 Series GPUs

Each GPU in the NVIDIA GeForce 6 and 7 Series contains three video processing engines—a programmable video processor (VP), an MPEG-2 decoding engine, and a motion estimation engine (MEE).

The revolutionary programmable VP adapts to new video algorithms as the algorithms become popular, instead of supporting only one standard. The PureVideo processor is a 16-way SIMD vector processor designed specifically for video algorithms.

The MPEG-2 decoding and motion estimation engines add compute power to smoothly play back MPEG-2 video and to make high-quality real-time video recording a reality without compromising your PC's ability to handle other playback and processing functions.

The NVIDIA GeForce 6 and 7 Series of GPUs serve as two chips—graphics processor and video processor—in one.

This technical brief describes the improvements to visual quality made possible by the additional computational power delivered by the programmable video processor, the motion estimation engine, and the video shader processing functionality of the NVIDIA GeForce 6 and 7 Series.

---

## PureVideo Adapts to New Standards

The heart of the GeForce 6 and 7 Series video improvement is a powerful 16-way SIMD vector processor optimized for macroblock-oriented video processing algorithms and YUV video data formats. This video processor builds upon the dedicated hard-wired circuits of earlier NVIDIA GPUs for MPEG-2 decode, color space conversion, video overlay, and high-quality video scaler (Figure 1). It accomplishes this by adding programmability that addresses new video formats (such as WMV9), future formats (such as MPEG-4), and H.264 for high definition.

Video shaders are programmable arithmetic processors that are typically used for performing 3D graphics operations at the pixel level. GeForce 6 and 7 Series programmable pixel pipes are perfectly suited for performing various video improvements in post-processing video operations in RGB color space. The resulting implementation offers enhanced video quality and video functionality. The more functions implemented on-chip as programmed video processor functions, the better the overall system performance during video operations.

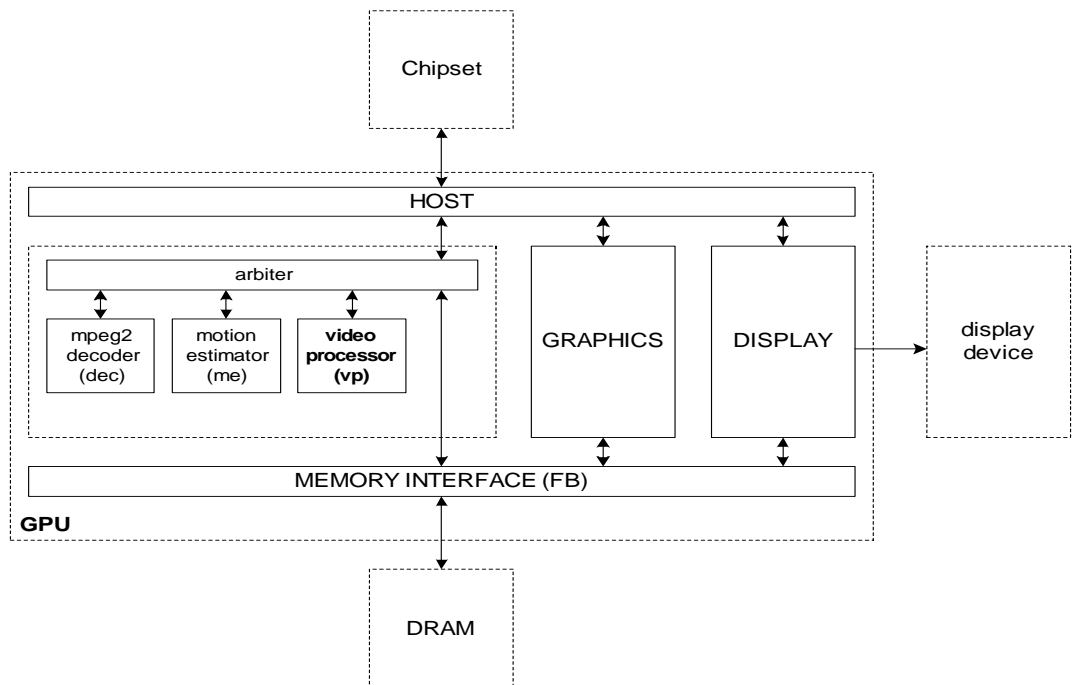

Figure 1. GeForce 6 and 7 Series GPU Architecture with VP and MEE

The NVIDIA PureVideo technology functions handled by the video processing engines in the GeForce 6 and 7 Series (Figure 2) are:

- ❑ Advanced spatial-temporal de-interlacing—Converts interlaced video for a progressive scan display using precise, content-based, adaptive algorithms to avoid video with jagged edges and feathering.
- ❑ Inverse telecine (3:2 and 2:2 pull-down correction)—Eliminates synthesized fields created during film-to-video conversion to produce higher-quality (vertical and temporal resolution) video.
- ❑ Bad edit detection and correction—Uses motion detection to identify the cadence of movement of onscreen objects and reliably plays the video without the jagged edges and flickering typically delivered with other PC-based video solutions.
- ❑ Color space conversion with extended color support—When the overlay circuit is not used, the video processor performs more accurate color space conversion (converting YCbCr to RGB), especially for HDTV content.
- ❑ Gamma correction—Optimizes gamma (nonlinear display characteristics) for specific content, relative to a specific type of display.
- ❑ Procamp function—Similar to color, tint, brightness, and contrast control on a television.
- ❑ High-quality VMR scaling—Upscaling or downscaling video for display to a window or specific display (LCD, CRT, television), or for use as a precompression step. Ensures video looks crisp, even on low-resolution content scaled to fit a high-resolution, high-definition display.
- ❑ Noise reduction—Reduces analog video noise usually found in broadcast or taped video sources. Reducing analog video noise makes the video look better, especially when the video is upscaled. Video noise reduction also improves video compression, enabling better video quality at lower bit rates.
- ❑ WMV9 motion compensation—The most computationally intensive aspect of WMV9 decompression is programmed on the video processor.
- ❑ WMV9—Deblocking eradicates the high-frequency “mosquitoing” or blockiness inherent in most compression transforms, and maintains sharp video output.

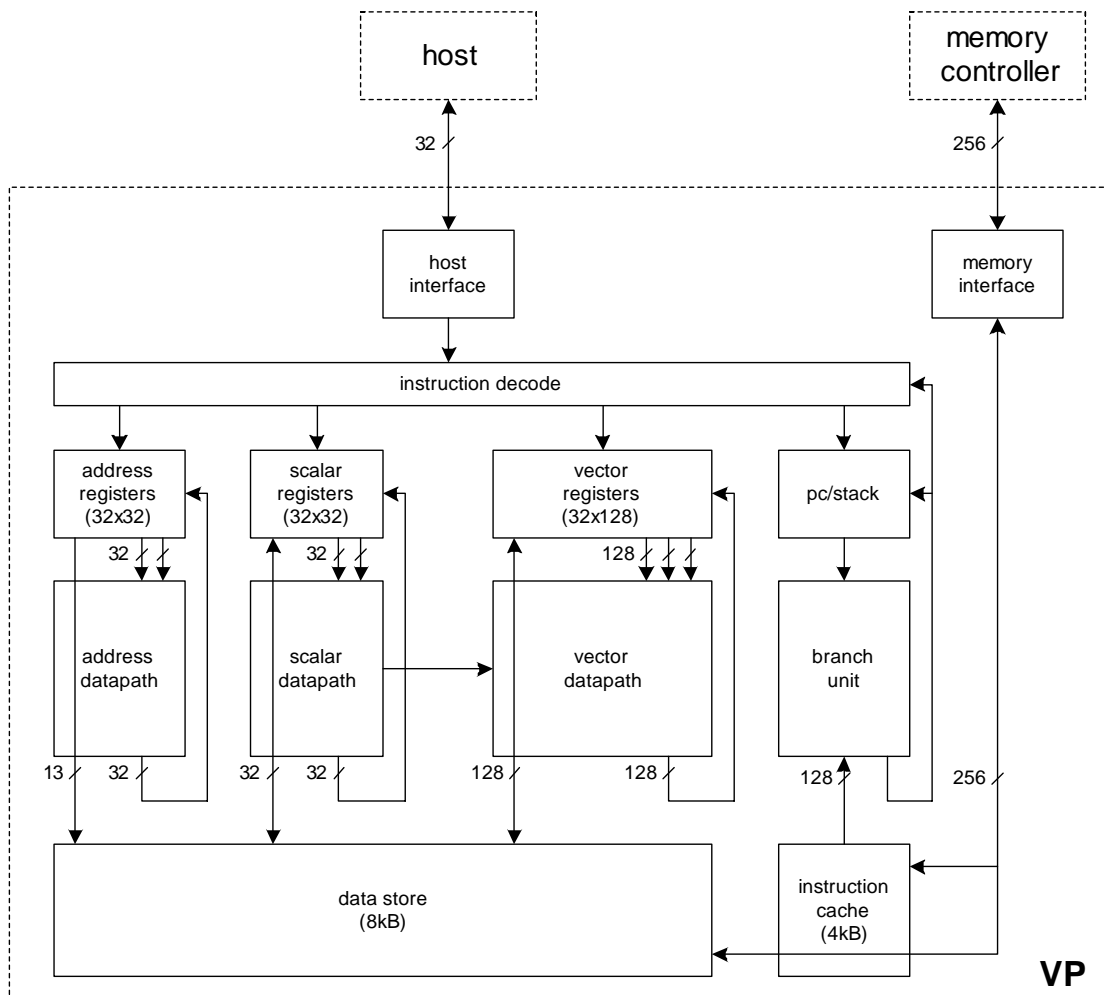

Figure 2. Internal Architecture of PureVideo Processor

## Video Recording (Encode)

The GeForce 6 and 7 Series of GPUs are capable of hardware video encode acceleration. Video encode is a difficult and time-consuming process. The power of the GeForce 6 and 7 Series of GPUs greatly reduces the time involved, and ensures the quality of the compressed video is top-notch.

Figure 3 illustrates the video encode process. The green blocks in the diagram indicate processing handled by the GeForce 6 and 7 Series of GPUs.

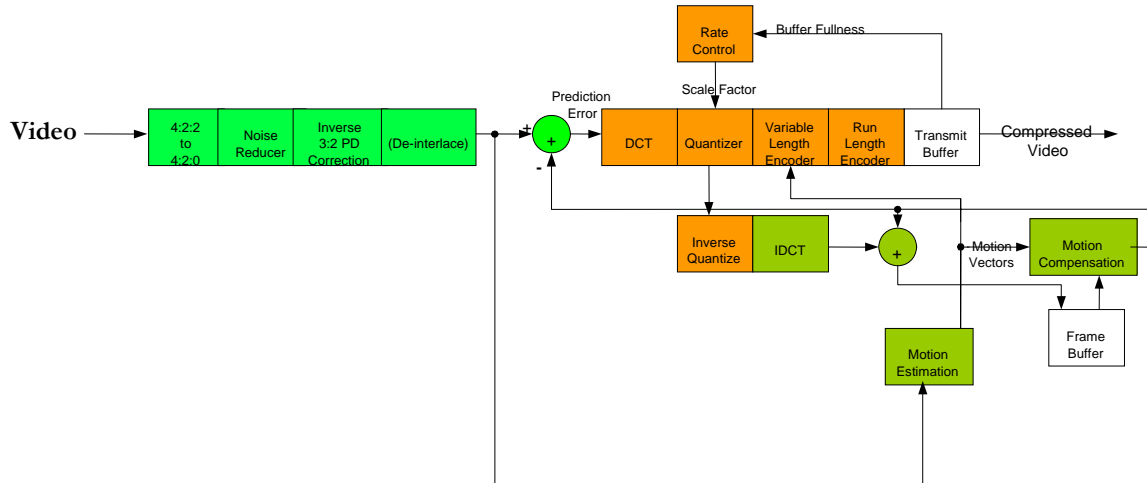

Figure 3. Video Encoding Pipeline

---

## Motion Estimation Engine (MEE)

For flawless video encoding and efficient support of digital video recorder (DVR) functionality, the NVIDIA GeForce 6 and 7 Series processors include a new motion estimation engine (MEE). Motion estimation is the most computationally intensive aspect of video compression. Often, parts of a scene move from one frame to the next. Instead of saving all the pixel values again, advanced encoding algorithms like MPEG-2, MPEG-4, and WMV9 save motion vectors. Once a block is encoded, the same data can be used for the next frame by calculating a motion vector to reflect the new location of that portion of the video.

Detecting motion in a scene is a compute-intensive task that used to require expensive, dedicated hardware. When a CPU is used for motion estimation, it is difficult to achieve real-time encoding, especially if the video is viewed at the same time. Personal video recorders (PVRs) support recording one video stream while watching a different, prerecorded video, so why don't PCs? Handling both tasks is typically too much for today's CPUs. Motion estimation accounts for over 50 percent of the workload of video encoding.

Now that NVIDIA GeForce 6 and 7 GPUs contain a dedicated motion estimation engine, video can be recorded and efficiently compressed in real time. Without a dedicated hardware video processor, video data is decimated and replaced by "blocky" video. The MEE maintains image detail by computing motion vectors, allowing data re-use while saving space for highly compressed, almost lossless video. The better the quality of the recording, the better the appearance of the video when it's played back.

The superior algorithms of the motion estimation engine on GeForce 6 and 7 GPUs yield higher-quality video, given the same (or lower) bit rate. They also use less of the CPU, which improves system performance. Figure 4 shows the difference between video that did not use motion vectors as part of the compression (left view), versus a recording that retained more of the original video content by including motion vectors (right view).



Figure 4. Difference in Recorded Video: No Motion Vectors (Left) vs. Motion Vectors (Right)

## High-Definition MPEG-2 Hardware Acceleration

The most common video format used today is DVD, which relies on video data encoded in MPEG-2 format. Figure 5 shows an example of the decode pipeline. The GeForce 6 and 7 Series of GPUs handle MPEG-2 decode with high efficiency and quality, offloading the CPU of any “heavy lifting” during MPEG-2 playback.

In Figure 5, the green blocks indicate the processing handled by GeForce 6 and 7 GPUs.

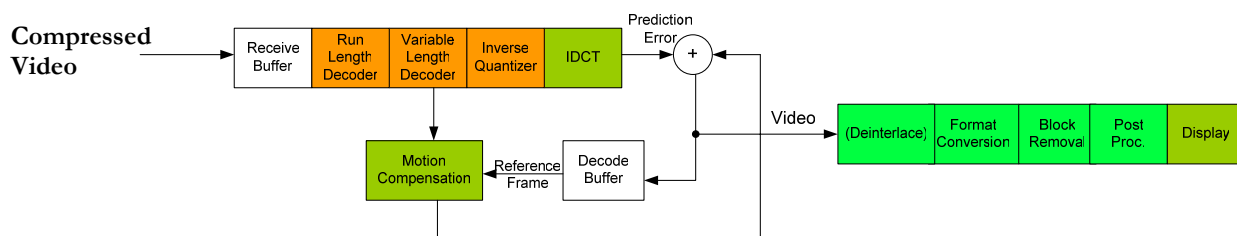

Figure 5. Block Diagram of MPEG-2 Playback

Motion compensation (MC) and inverse discrete cosine transformation (IDCT) are the two most computationally intensive aspects of MPEG-2 decoding.

- MC restores the temporal (interframe) differences to full frames or fields.
- IDCT converts data from a frequency domain of coefficients to spatial or pixel data.

The excellence of the NVIDIA implementation is evident by the absence of frame dropping and the low CPU utilization, especially during scene transitions. In fact, NVIDIA GPUs handle over 95 percent of the decode workload. As a result, frame rates are smooth and power usage is reduced on notebooks. For standard DVDs you may not notice much difference, but when you play back high-definition video that can be six times the workload, hardware acceleration can be the difference between seeing the full movie versus watching the equivalent of a slide show.

---

## WMV HD Hardware Acceleration

Most PC video solutions are hard-wired for MPEG decoding. PureVideo processors are programmable to support any video format (Figure 6), such as Windows Media High Definition (WMV HD). As with motion compensation for MPEG-2, the NVIDIA video engine can perform most of the computation-intensive work, leaving lesser aspects to the CPU. This capability is important for notebooks—it lets the video processor use less power than the CPU to do the same work, which means battery life can be extended, for example, while a consumer watches a movie. It is also important if you plan to watch videos while recording other programs in the background.



Figure 6. Scene from Video Encoded in WMV HD Format Decoded by GeForce 6 and 7 Series GPU with PureVideo

Encoding and decoding video in standard formats is only the beginning for delivering pure video quality. Today's video compression algorithms are not lossless. Playing back encoded video leaves room for improvement. A lot of video content is created for viewing on TV, so it's stored for playback on an interlaced display. Finally, every display type has different color reproduction characteristics that require post-processing to deliver the image the director intended.

A high-quality, consumer electronics experience demands that these additional video processing aspects be handled.

## Advanced Spatial-Temporal De-Interlacing

De-interlacing converts interlaced content, such as a television signal, to progressive scan content. This process is required because VGA displays and LCDs can only display progressive content.

PureVideo technology on the GeForce 6 and 7 GPUs includes intellectual property that implements advanced de-interlacing techniques. These techniques ensure the sharpest images, with no saw-toothed, jagged, diagonal lines. They make scene and pixel-by-pixel decisions about filtering and motion detection (interframe), and filter accordingly, using more advanced processing than other PC solutions.

As illustrated in Figure 7, the PureVideo de-interlacing solution is superior because it removes the jagged edges and false colors common with interlaced video.



Figure 7. Competitive De-interlacing vs. PureVideo Advanced Spatial-Temporal De-Interlacing

With the introduction of the new NVIDIA GeForce 7800 GTX GPU and NVIDIA ForceWare™ Release 75 driver, NVIDIA extends its PureVideo advanced de-interlacing capabilities to computationally intensive high-definition (HD) content (Figure 8).



Figure 8. Competitive HD De-Interlacing vs. PureVideo Advanced Spatial-Temporal HD De-Interlacing

## Inverse Telecine (3:2 and 2:2 Pull-Down Correction)

Most video content was originally captured on film at 24 frames per second (fps). However, television typically displays at around 25 fps or 30 fps. The process of converting film (cinema) content to television format is called 3:2 and 2:2 pull-down. To match the different display rates, additional fields are inserted in the video stream (Figure 9).

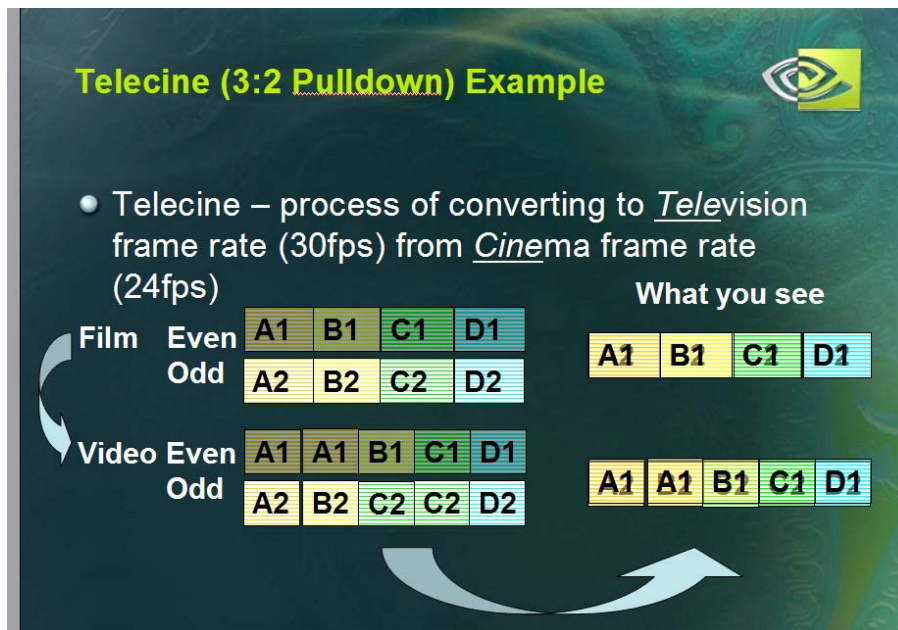

Figure 9. Example of 3:2 Pull-Down Correction

When this content is displayed on a progressive display like a PC screen, the inserted frames can appear fuzzy.

The sequence of images in Figure 10 shows a side-by-side comparison of 24 fps film content converted to 30 fps video. The left view shows the artifact created by inserting Frame 2 and Frame 3, and the right view shows the recovered video content displayed with NVIDIA's inverse telecine processing. Notice that the image on the right looks clear frame after frame, whereas the image on the left is blurry in two frames.

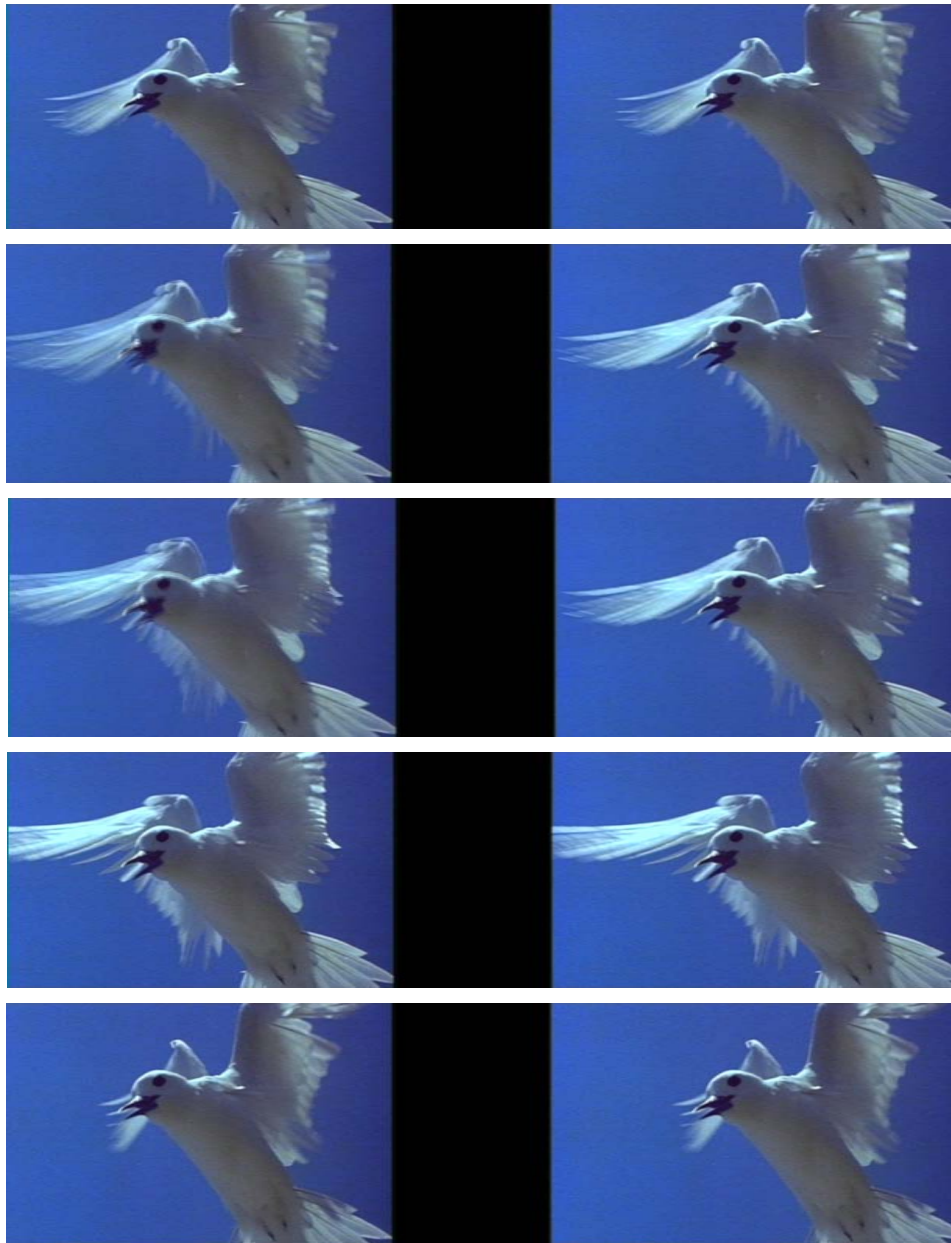

Figure 10. Film Content Converted from 24 fps to 30 fps



Figure 11. The 3:2 Pull-Down Correction Recovers Original Content and Displays Clean Images Frame After Frame

---

## Bad Edit Detection and Correction

Film content is often converted to video before it is edited. Post-conversion editing can destroy the 3:2 standard cadence that video decoders expect.

Many consumer players—and all PC solutions so far—have not corrected this problem; the result is jagged-edge artifacts, like the edges of chrome grill on the fire truck in Figure 12 (left view). These artifacts appear in every video frame displayed and can display jerky vertical movement of objects.



Figure 12. Artifacts in Video Image (Left) vs. No Artifacts with PureVideo Edit Detection and Correction (Right)

By applying advanced video stream analysis, the NVIDIA solution detects invalid edit tags and uses a unique inverse telecine algorithm to correct the image, frame after frame.

---

## Multistream VMR Scaling

As the PC becomes the center of media operations, new video-enabled Media Center Edition operating systems and applications are being designed to support the display of multiple video streams at any time. Video streams can be composited, edited, and manipulated on the fly. Welcome to the Video Mixing Renderer (VMR) world! The GeForce 6 and 7 Series VP produces high-quality 4-tap horizontal and 5-tap scaling. This advanced scaling ensures accurate and clean-looking video, whether it is low-resolution video from a camera phone upscaled to a high-definition display, or high-definition content downscaled to fit in a picture-in-picture window without spatial or temporal artifacts.

The following screenshots (Figure 13) are from a typical video found on a Web site promoting tourism. When this video is scaled to full screen on a UXGA display, the difference between typical scalers and the high quality of the GeForce 6 and 7 Series PureVideo processing becomes very apparent.



Figure 13. Typical Scaler vs. PureVideo Scaler

Notice the jagged edges on the window frames in the picture on the left. Notice also the mottled red background behind “35,000,” and notice the edges of the characters. In the picture on the right, notice that the lines are smoother, the text background is a solid color, and the text edges are well defined and round.

## LCD Sharpening

Liquid crystal displays (LCDs) work on the property of direction-dependent permittivity of light. A typical TFT-LCD (thin-film transistor LCD) panel has two glass plates filled with liquid crystal. One glass plate has TFTs for each pixel; the second glass plate has a color filter for each pixel, which helps generate color.

The amount of light supplied by the backlight at each pixel is determined by the orientation of the liquid crystals at the pixel location. Gray scale—the degrees in the amount of light between full brightness and full opaqueness—can be obtained by applying a voltage between the color filter glass and the TFT glass to orient the liquid crystal.

LCDs have an inherent problem: the gray scale transition (implying reorientation of liquid crystals) can take several refresh intervals to complete. To make matters worse, small changes in gray scale can take longer to complete than full white-to-black and black-to-white transitions. The slower response of the LCD causes motion blur and ghosting artifacts in high-motion video.

The NVIDIA LCD Sharpening technology anticipates the brightness level of the next screen refresh. Instead of waiting for the next frame, it momentarily illuminates each pixel with a color higher or lower than what is needed to achieve the required gray scale transition in time. The reliability of the display is not compromised, nor is the longevity of the panel reduced.

When conventional driving is applied, the transition from grayscale  $Y_{in}$  to grayscale  $Y_{out}$  may not be reached in one refresh interval. Therefore, an overdrive signal YOD is chosen and applied as a substitute so that the desired grayscale transition to  $Y_{out}$  is achieved in the next refresh interval. This eliminates the characteristic lag natural to all LCD panels (Figure 14).

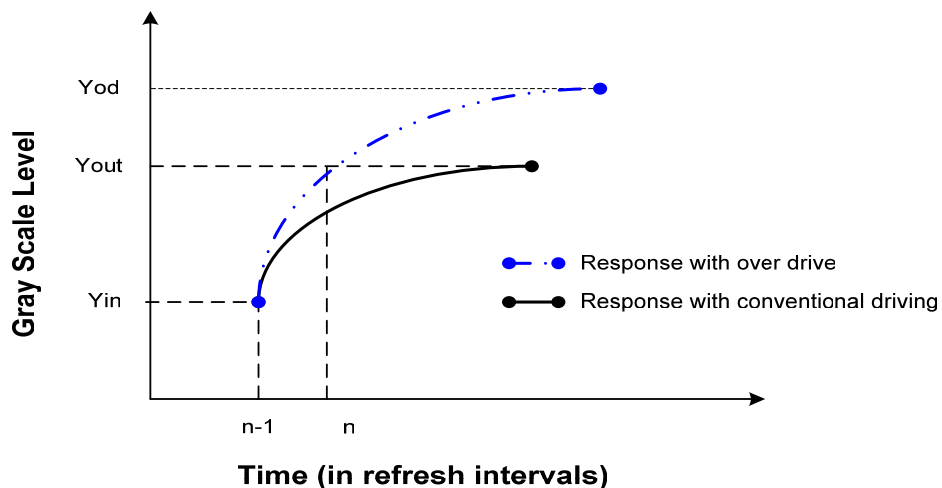

Figure 14. LCD Sharpening Method

---

## PureVideo on the Go

As the mobile notebook PC becomes the platform of choice among consumers, Pure Video technology will be even more relevant to PC users. Whether at home or on an airplane, users expect crystal-clear video while watching a movie on a DVD or playing back prerecorded television clips.

The battery life of the notebook is paramount when traveling. With the dedicated video processor of the GeForce Go 6 and GeForce Go 7 Series GPUs, maximum battery life is preserved. By only utilizing purpose-built video circuitry, the GPU offloads functions from the processor that cannot achieve the same efficiency using its general-purpose computing blocks.

---

## CPU Utilization

To conserve battery life, NVIDIA's PureVideo technology delivers the sharpest video with the most efficiency. Using purpose-built video processing blocks, the GPU offloads calculations off the CPU and into the GPU's more efficient video processor, reducing power consumption and increasing battery life.

Figures 15 and 16 illustrate the difference in CPU usage between processing high-definition (HD) video on the CPU and on a GeForce 7 series GPU, respectively. In this example, a savings of 9 W is achieved, which can mean up to 15 minutes more viewing time by just using the dedicated video processor.

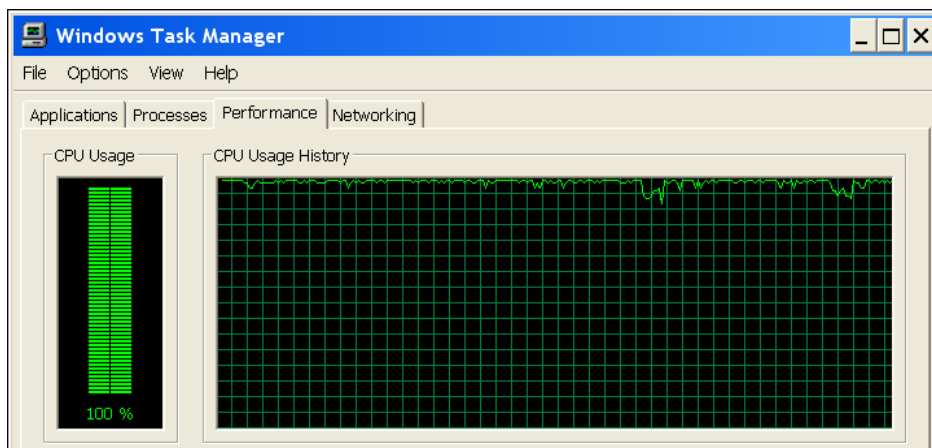

Figure 15. HD Software Decode Without Hardware Acceleration on the CPU

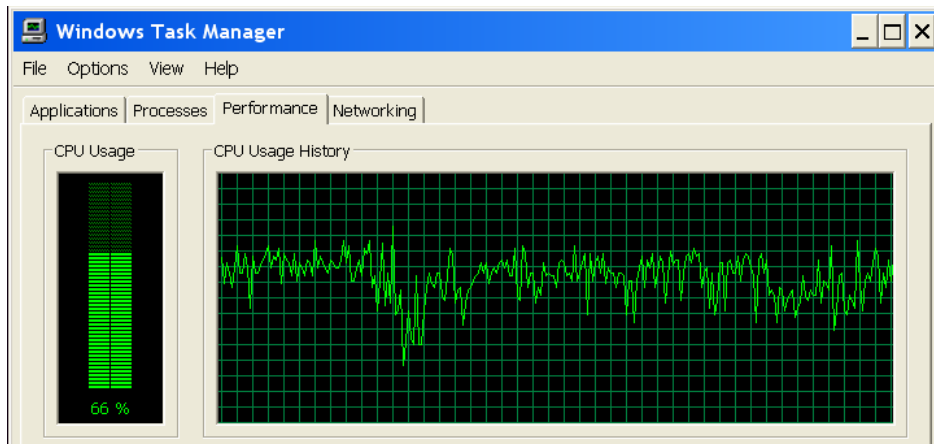

Figure 16. HD hardware Decode on the GeForce's Dedicated Video Processor

---

## Conclusion

NVIDIA's PureVideo technology, found exclusively in the GeForce 6 and 7 Series, deals with the explosion of digital media formats within the PC world and delivers better than consumer electronics-quality video playback and recording. The powerful GeForce 6 and 7 Series PureVideo processor and MEE provide the compute power to run more advanced algorithms to deliver better video quality that other graphics solutions just can't match.

PureVideo is not just a high-end offering...PureVideo is built into NVIDIA's complete top-to-bottom product family, providing a valuable addition to mainstream and corporate desktop and notebook PCs.



## Notice

ALL NVIDIA DESIGN SPECIFICATIONS, REFERENCE BOARDS, FILES, DRAWINGS, DIAGNOSTICS, LISTS, AND OTHER DOCUMENTS (TOGETHER AND SEPARATELY, "MATERIALS") ARE BEING PROVIDED "AS IS." NVIDIA MAKES NO WARRANTIES, EXPRESSED, IMPLIED, STATUTORY, OR OTHERWISE WITH RESPECT TO THE MATERIALS, AND EXPRESSLY DISCLAIMS ALL IMPLIED WARRANTIES OF NONINFRINGEMENT, MERCHANTABILITY, AND FITNESS FOR A PARTICULAR PURPOSE.

Information furnished is believed to be accurate and reliable. However, NVIDIA Corporation assumes no responsibility for the consequences of use of such information or for any infringement of patents or other rights of third parties that may result from its use. No license is granted by implication or otherwise under any patent or patent rights of NVIDIA Corporation. Specifications mentioned in this publication are subject to change without notice. This publication supersedes and replaces all information previously supplied. NVIDIA Corporation products are not authorized for use as critical components in life support devices or systems without express written approval of NVIDIA Corporation.

## Trademarks

NVIDIA, the NVIDIA logo, ForceWare, GeForce, and PureVideo are trademarks or registered trademarks of NVIDIA Corporation in the United States and other countries. Other company and product names may be trademarks of the respective companies with which they are associated.

## Copyright

© 2005 NVIDIA Corporation. All rights reserved.



**NVIDIA.**

NVIDIA Corporation  
2701 San Tomas Expressway  
Santa Clara, CA 95050  
[www.nvidia.com](http://www.nvidia.com)